

HANDWHEEL GEARBOX OPERATOR Type MG

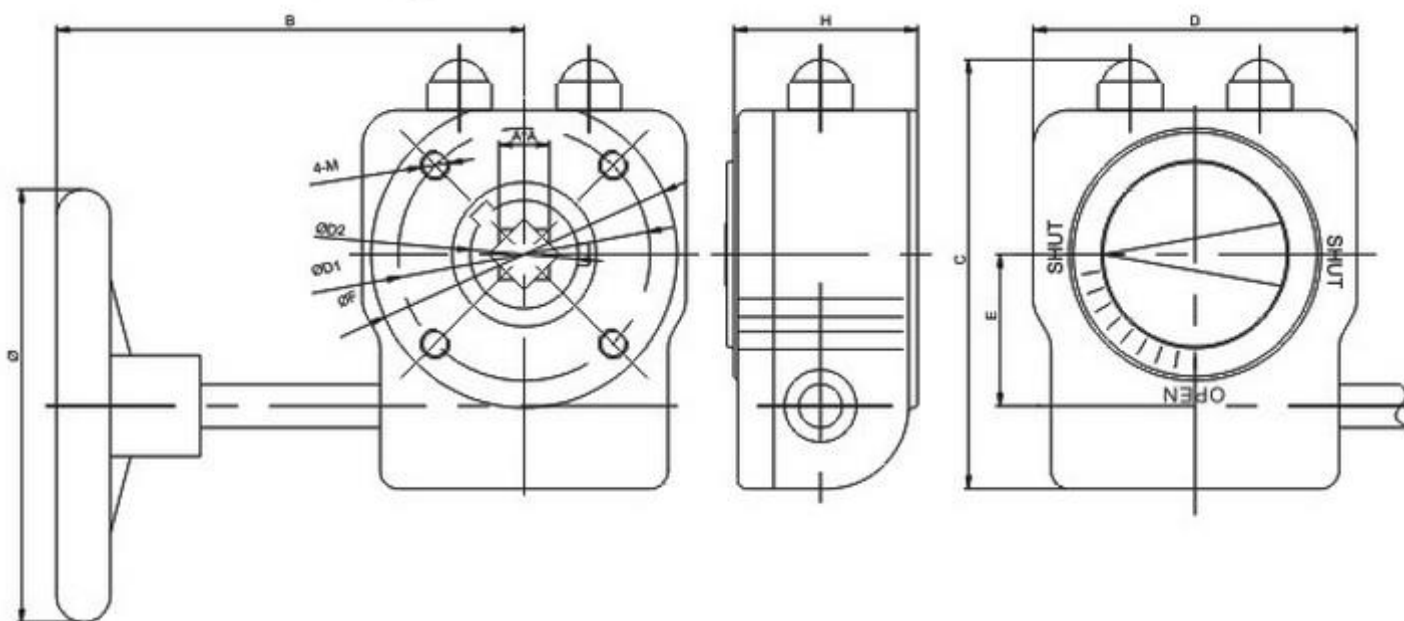

Description

- aluminium body
- filled with special lubrikant
- connections acc. to ISO5211
- waterproof acc. to IP65
- output torque range: 180-1310 N.m.
- 5 degree angle adjusting



Dimensions

Type	ISO 5211	Torque /N.m/	AxA	B	C	D	E	F	H	ØD2	Ø	4-M	Weight /kg/
MG070	F05/F07	180	9x9;11x11;14x14;17x17	160	115	80	42	78	48	30	140	M6/M8	1,6
MG090	F07/F09	300	9x9;11x11;14x14;17x17	160	130	100	50	97	54	32	200	M8/M8	1,8
MG102	F07/F10	540	17x17;19x19;22x22	215	150	120	60	117	56	43	250	M8/M10	3
MG125	F10/F12	675	17x17;19x19;22x22	225	180	142	60	138	69	43	300	M10/M12	5
MG140	F14	1310	22x22;27x27	325	225	185	80	175	95	54	400	M16	10
MG140B	F14	1790	22x22;27x27xØ50x14	375	225	185	81	175	95	50	600	M16	13
MG165	F16	3250	36x36;Ø50x14	395	268	230	104,5	220	105	65	600	M20	20
MG254	F16/F25	5500	Ø60x18;Ø65x20;Ø80x22	416	332	265	130	286	125	80	700	M20/M16	25

No.	Part	Materials	Optional material
1	Body	Aluminium Alloy	
2	Worm gear	Ductile Iron QT400-15	
3	Worm	Carbon steel	
4	Shaft	Stainless steel	Stainless steel
5	Handwheel	Carbon steel	
	Screw	Stainless steel	Stainless steel

