

LIMIT SWITCH BOX TYPE MB-1

Description

- spherical position indicator
- standard IP67 covered
- mechanical switches
- AC 250V 3A, DC 250V 0.2A, 125V 0.4A, 8/15V 5A
- fully adjustable spring loaded cams
- easy adjustable bracket acc. to NAMUR
- body and cover made of die-casted aluminium



Bracket types

Mounting dimensions (mm)

30x80 H=20
30x80 - 30x130 H: 20-30 / 40-50 adjustable

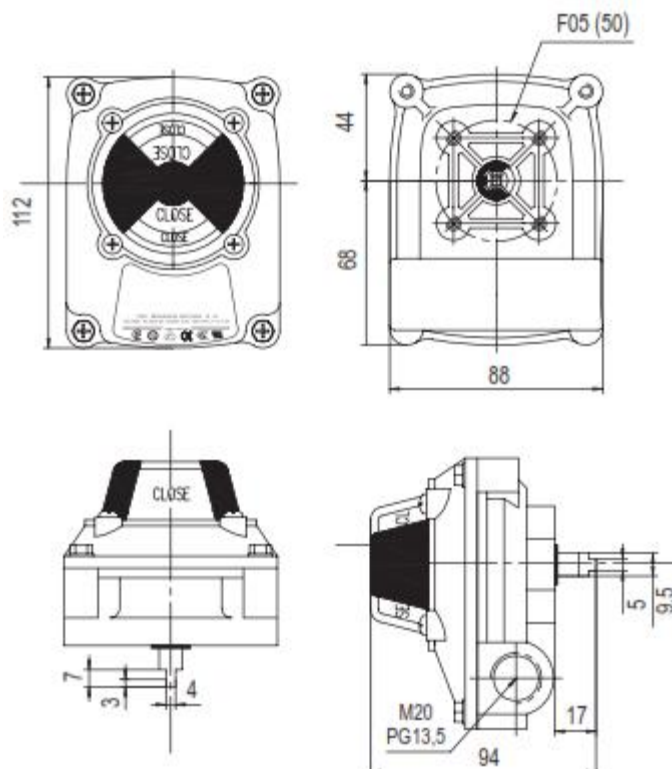
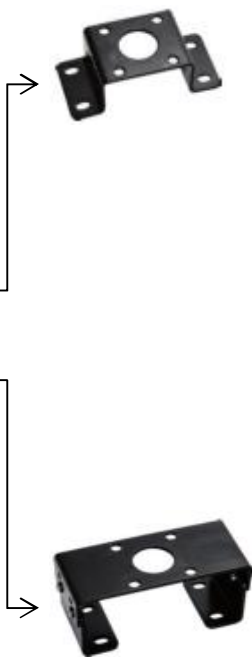

Connection Diagram

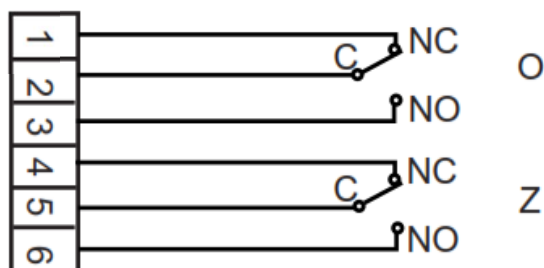

LIMIT SWITCH BOX TYPE MB-1

Components - specification

No.	Part name	Material	Qty.
1	Spacer	Brass	1
2	Stem	SS420	1
3	Cam-1	Delrin	2
4	Cam-2	Delrin	2
5	Spring	SS420	1
6	Stem O-Ring	NBR	1
7	O/C Indicator	ABS	1
8	Indicator Glass	ABS	1
9	Body	Aluminium (die-cast)	1
10	Cap	Aluminium (die-cast)	1
11	Cam O-Ring	NBR	1
12	Washer	SS304	4
13	Cap Screw	SS304	4
14	Cam Screw	SS304	4
15	Switch		2
16	Switch Spacer	Plastic	2
17	Washer	SS304	2
18	Switch screw	SS304	2
19	Terminal screw	SS304	2
20	Terminal	Plastic	1
21	Terminal cable screw	SS304	16
22	Cable set		1
23	Circlip	SS304	1
24	Blind plug	Plastic	1
25	Plug	Plastic	1
26	MB1 bracket	Steel	1
27	MB2 bracket	Steel	1
28	Adjustment washer	SS304	4
29	Bolt	SS203	4
30	Cam Pin	Mild steel	2
31	Body seal	NBR	1

